



Your Made
furling boom

OWNER'S MANUAL

Type S Manual drive system

The information contained in this handbook is to be used as a guide for the safe installation, operation and maintenance of the Made Type S in boom furling system.

Contents

1.	Components packing list	2
2.	Installation.....	5
2.1	Preparing the mast	5
2.2	Fitting the Leisure furl sail track	6
2.3	Fitting the mast components.....	8
2.4	Fitting the boom and mandrel	8
2.5	Deck lay-out	9
2.6	Sail fitting instructions	10
2.7	Checklist after installation	11
3.	Operation	12
3.1	Setting up boom height.....	12
3.2	Hoisting the sail.....	13
3.3	Furling the sail	13
3.4	Controlling the sail.....	14
3.5	Sail adjustments	16
3.6	Operating tips.....	17
3.7	Trouble shooting.....	18
4.	Maintenance	20
5.	FAQ.....	21
6.	Glossary of terms.....	23
7.	Contact details	24
8.	Disclaimer	25

1. Components packing list



Boom shell	Aluminum or Composite
Mandrel	Aluminum or Composite
Mast track system	Leisure furl track or head car supportable track
Drive system	Manual operation with Dyneema line
Back-up	Back-up recess for winch handle
Sheeting system	Reinforced pad-eyes or tailored solution
Boom vang bracket	Reinforced bracket to match pin and jaw
Support bracket	Internal structure to retain the mandrel
Sail cover	Integrated and retractable sail cover
Topping lift bracket	Stainless steel mounting bracket
LED light	Option
Boom vang	Option



1.	Furling line
2.	Spool and drum for manual operation with locker and back-up recess
3.	Universal coupling connected to spool with through-mast shaft
4.	Aluminium or carbon fibre furling mandrel
5.	Gooseneck bracket with vertical pin and washers (option)
6.	Gooseneck toggle with horizontal pin and washers
7.	Sail cover retraction line
8.	Retraction line clamp (apply by default)
9.	Reinforced boom vang lug

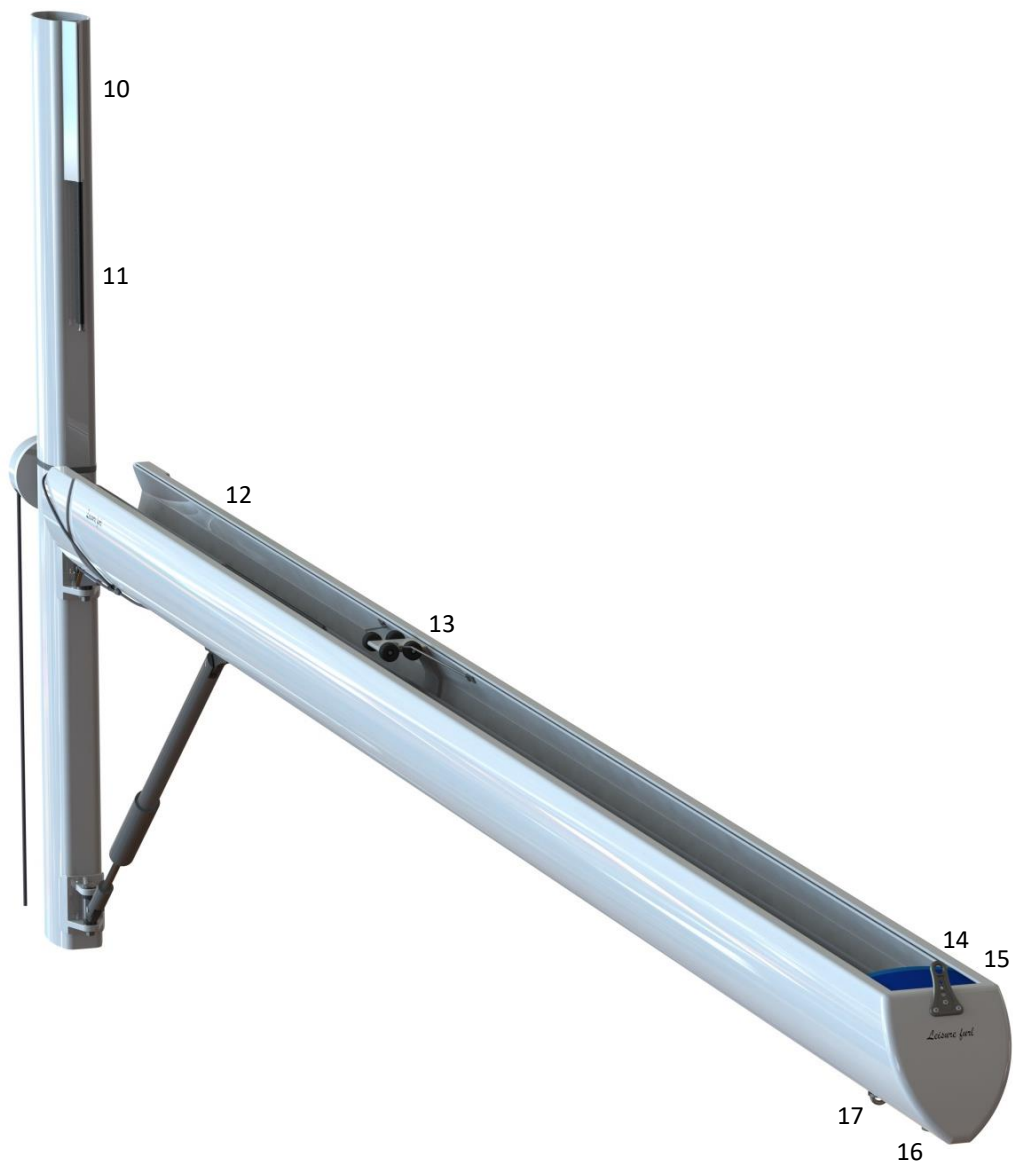

10.	Leisure furl luff track or head car supportable luff track
11.	Flexible feeder and pre-feeder
12.	Aluminium or carbon fibre boom shell
13.	Support bracket with rollers and sail cover guides
14.	Integrated retractable sail cover
15.	Topping lift bracket
16.	LED light (option)
17.	Pad-eye(s) for sheet and preventer

2. Installation

There are 7 stages to fitting the leisure furl system:

1. Preparing the mast
2. Fitting the sail track
3. Fitting the mast components
4. Fitting the boom and mandrel
5. Deck lay-out
6. Fitting the sail
7. Checklist after installation

Important

- It is recommended to unstep the mast and position it horizontally (face down) during step 1-3.
- The area on the aft side of the mast should be clear from obstructions or sharp edges.
- Before removing or installing any component, check this manual for instructions.
- The boom should not be raised or lowered more than 10° to its default angle of 90° to the mast.
- The sail cover retraction line should always be clamped, so it cannot get caught by the sail when furling.

2.1 Preparing the mast

Before any parts are mounted to the mast, first mark the P-measures on the mast. "P" refers to the luff length of the mainsail.

At the top of the mast, just below the topping lift sheave, mark "TOP P". Consider the angle the topping lift will exit at so the topper will clear as the boom articulates. Mark "bottom P" on the mast by measuring the luff length from "top P". This mark specifies the sail foot position as well as the top of the furling mandrel.

From "bottom P" set marks at the following positions:

- X: the distance between "bottom P" and start of luff track
- Y: distance between "bottom P" and centre of mandrel
- Z: distance between "bottom P" and the underside of the upper gooseneck lip.

The exact values for X, Y and Z will be provided on a custom drawing. Ask for this drawing if you have not received it.

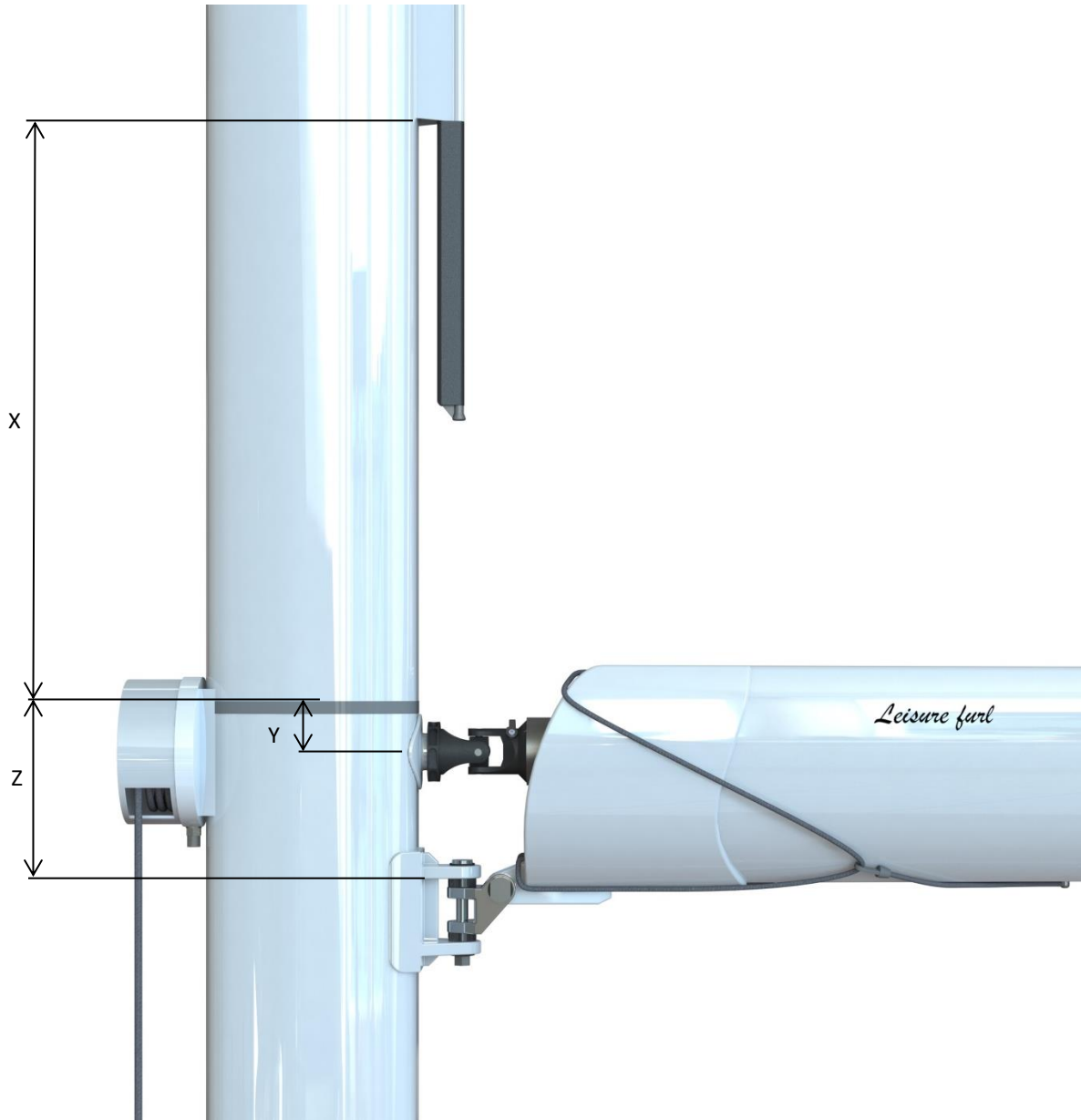

2.2 Fitting the Leisure furl sail track

Position the track on the mast. Use masking tape to secure the track to the mast. Drill on both sides of the track using a 5 mm drill and fit a Monel rivet to each hole before you drill the next. This way the track will not move against the mast, misaligning the holes. Ensure the track ends are free from sharp edges and line up

neatly. Luff tape damage could result if misaligned. Drill each track end using 4 rivets on each side at 20 mm centres from the bottom and top edge. Clean all the holes on the mast and radius the edges.



The bottom section of sail track will need cutting to length at the position where the track finishes (mark X). Once cut to the finished length, deburr the track end and radius the sides carefully. Luff tape damage could result if the track end is not deburred and the luff groove is not rounded off.

It is essential that the feeder be correctly positioned at all times, so as to ensure the load of the sail is taken on the feeder, not the sail track. Incorrect alignment may reduce the life of the luff tape, and risks the sail not entering the sail track correctly.

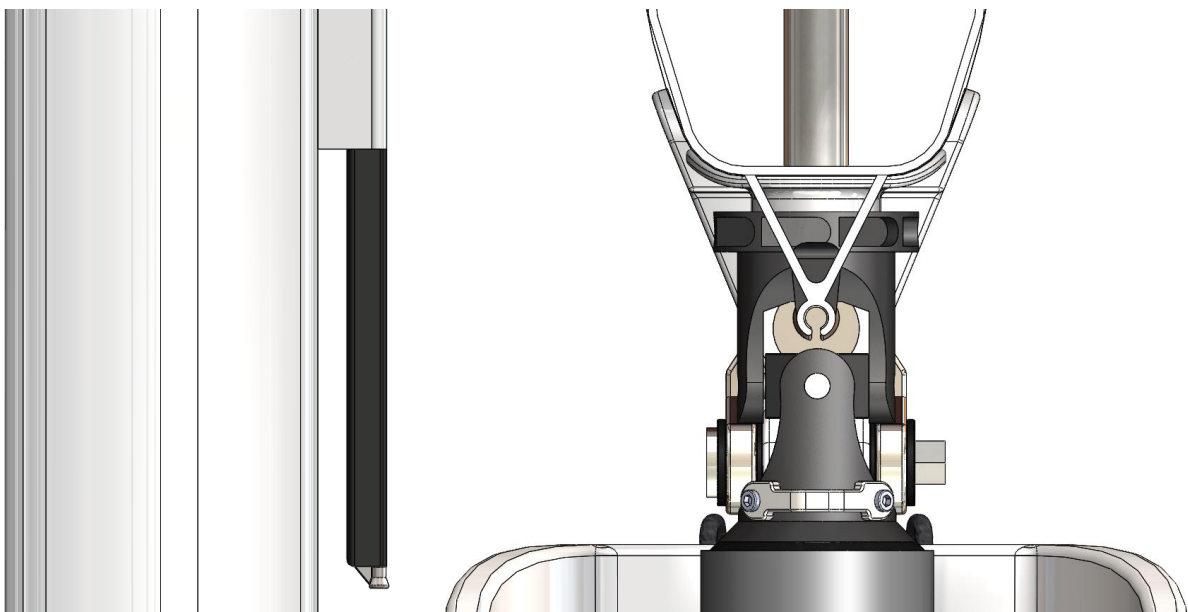

2.3 Fitting the mast components

The centre of the shaft that goes through the mast must align with the centre of the mandrel (mark Y). Drill a hole through the aft side of the mast at mark Y. The diameter of the hole should be slightly larger than the diameter of the shaft. Deburr the hole on the inside and outside of the mast such that there are no sharp edges. Drill another hole on the front side of the mast at mark Y in a similar way. The holes must line up horizontally (90 degree angle to the mast). Again, deburr the hole on the inside and outside of the mast.

Align the aft bearing with the hole on the aft side of the mast and drill and tap according to pattern. It is advisable to drill, tap and fix the top and bottom hole before you drill, tap and fix the other holes to make sure everything aligns perfectly. In a similar way, install the drum in front of the mast. Use Tef-Gel to protect the aluminium mast against the stainless steel bolts.

Position or reposition the gooseneck bracket according to the instructions (mark Z).

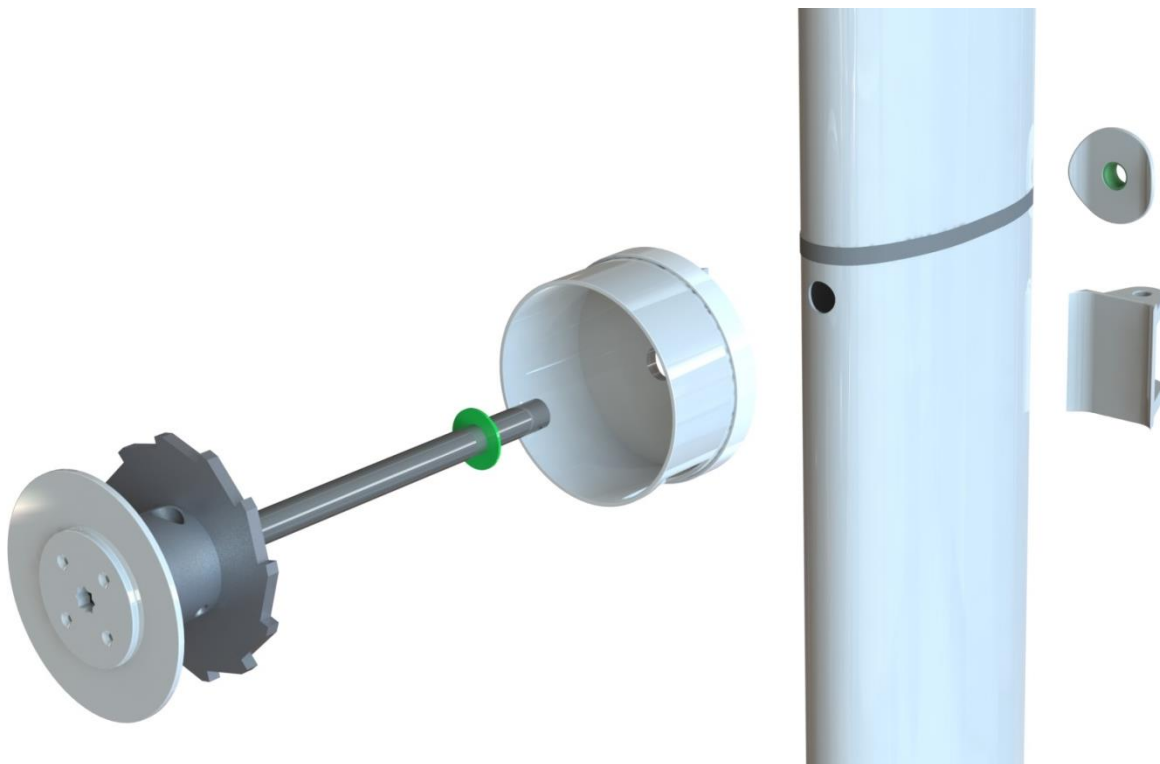

2.4 Fitting the boom and mandrel

With the mandrel positioned inside the boom shell and end-bearing, lift the boom into position on the boat. Preferably, use a crane. Alternatively, use the halyard to lift the front of the boom and use the topper to lift the aft of the boom, and manoeuvre the front of the boom by hand or with a secured control line to the mast.

Attach the boom to the gooseneck bracket using the vertical pin. Make sure all washers are in place to avoid clearance.

It is important to keep the vertical angle between the boom and mast approximately 90 degrees during and after the installation. This is because the boom and mandrel are installed on the mast independently. So the mandrel will slide inward when the boom is lowered and outward when the boom is raised. The vertical angle between the boom and mast must always stay within the range of 80°-100°.

When the boom is mounted, it is advisable first to mount and fix the boom vang in order to unload the topper. After that, the mandrel can be mounted to the mast.

Slide the universal coupling (with mandrel) onto the drive shaft until the coupling touches the aft bearing. The drive shaft should not protrude further than the opening in the coupling. If the shaft is too long, it will jam the universal in operation and cause the system to seize.

To mount the drive shaft to the coupling, fit the pin through the coupling and shaft. Lock the pin with grub screws and Loctite.



2.5 Deck lay-out

Consider the lay-out for leading the halyard and furling line aft. The rope guide should lead the furling line off the spool parallel to the mast from the spool center.

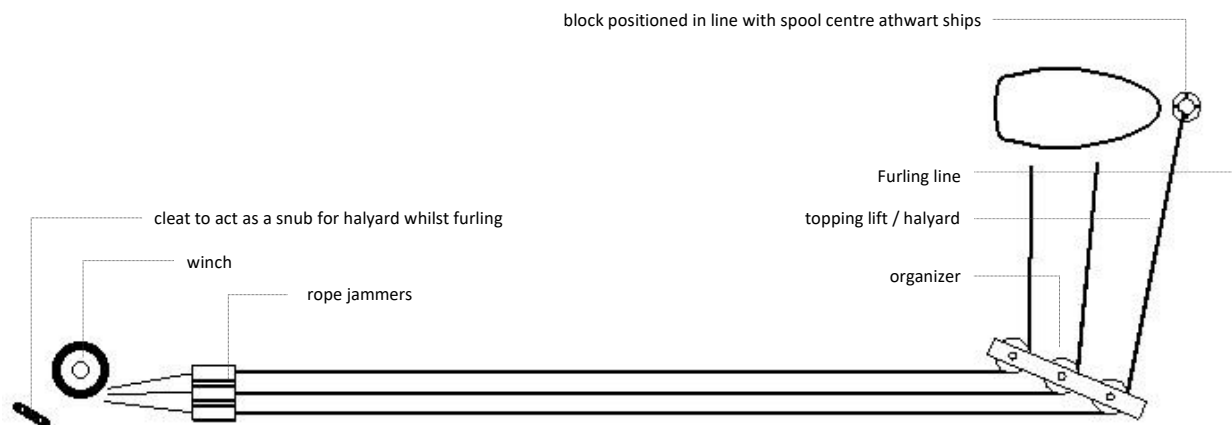

It is essential that the mainsail remains visible during both hoist and furl, so position the operating switch and control lines in the helm in a position to allow this. Generally the winch will be converted to an electric driven winch or capstan. Use of the rope jammer will determine the position for operation. The operating switch should be positioned in such a way to allow the operator the freedom to use both hands for managing the boat. Consider positioning the switch on the helm floor or side wall, and depress the switch using the foot or knee.

2.6 Sail fitting instructions

With the sail laid on port side, lift the sail foot up towards the furling mandrel. Then slide the foot bolt rope into the foot track on the mandrel from either forward or aft. Attach first the tack to the furling mandrel, leaving around 30mm between the tack web and tack ring on the universal. Now lash the clew to the outhaul saddle on the mandrel. Do not pull the foot out tight, leave fullness in the foot for efficient downwind sailing. The built-in sail controls will generate outhaul tension. Lash also the clew to the furling mandrel using a separate lashing, pulling the clew within 10mm of the mandrel.

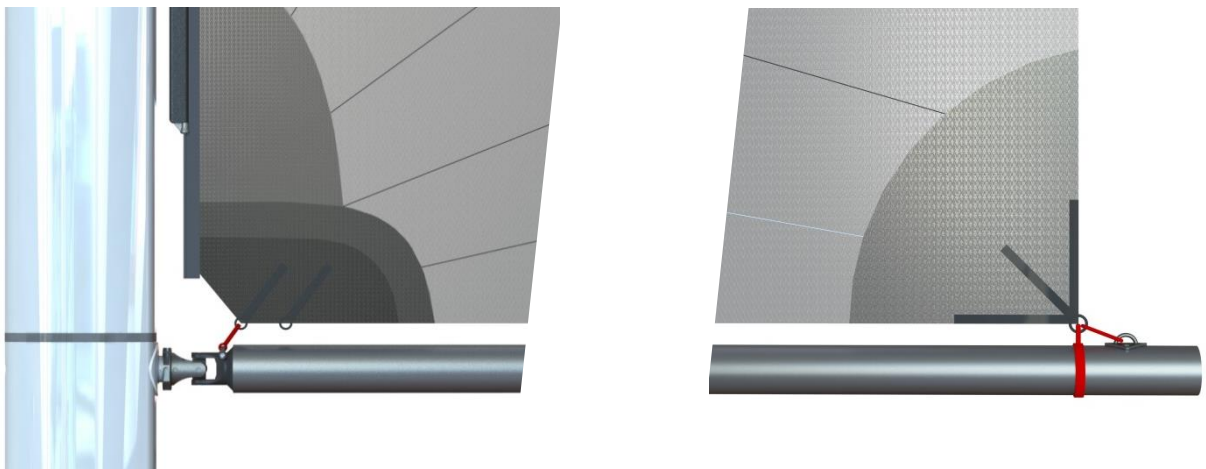

Use the electrical winch or use the winch handle (inserted into the spool face plate) to roll the sail onto the port side of the mandrel (clockwise when facing aft). Two persons should assist by pulling either the luff or leech, so as to ensure the bolt rope remains in the area between the boom edge and the mast, whilst the sail is being furled.

Alternatively, hoisting the sail from the deck may be preferred, as the boom height from the deck may inhibit manual fitting. In this instance the furling line will need to be pre-wound on the spool before the sail is attached - and the boom set to the correct angle for furling - before the sail is hoisted.

With the sail rolled on the mandrel, fasten one end of the furling line to the spool by first placing 5 turns around the spool drum in a counter-clock direction, looking aft. Then pass the free end through the hole in the spool. Tie a single knot as close as possible, and push the knot into the counter bore of the spool drum.

2.7 Checklist after installation

If any of the following points are not complete, the system could be damaged.

1. Ensure the halyard sheave is set correctly, with no chance of chafe on either the halyard or topper.
2. Ensure the track joins are aligned and deburred.
3. Ensure the feeder's alignment with the sail track is set up correctly.
4. Ensure the spool spins freely.
5. Ensure all machine screws have been treated with anti-corrosive compound.
6. Ensure there are no objects or sharp edges between the feeder and gooseneck for the sail to catch on.
7. Ensure the drive shaft does not protrude through the back face of the universal drive coupling.
8. Ensure the furling line is lead aft and the rope guide is set correctly for alignment from the deck to the spool.
9. Ensure the boom angle to mast is not limited by the vang or topper adjustment.
10. Ensure the vang can support the weight of the boom.
11. Never raise or lower the boom more than 10%.

3. Operation

This section explains:

1. Setting up boom height
2. Hoisting the sail
3. Furling the sail
4. Controlling the sail
5. Adjusting the sail

3.1 Setting up boom height

To establish the correct operating angle for the boom, once at full hoist, over tension the main halyard. This will give an accurate indication of the tack angle. Pull on the topping lift, tie this off and mark a position for future reference, as this is the correct position for furling. Release now the topper if interfering with the mainsail. It is possible for the topper to stretch, so review the height as above regularly.

Release the load of the main halyard until wrinkles appear at the luff. Engage the main halyard jammer, and mark a position for reference on the main halyard. This position will become the maximum hoist. With the foot track on the mandrel in its uppermost position, ensure adequate fullness has been allowed for. This should now be a full and powerful downwind sail.

With the main halyard jammer still engaged, pull on the furling line. This will flatten the foot and tension the luff, as if an outhaul and cunningham had been applied. This becomes an efficient up wind sail. When the furling line is released, the mandrel will rotate back to the downwind position (only when the locker is not in use - disengaged).

Now set up the reef points for the sail:

- Snub the main halyard around a winch or T cleat, to take the halyard load once the jammer is released.
- Release the main halyard rope jammer, ensuring load on the halyard is maintained.
- Pull in on the furling line, as you ease the main halyard. Apply the desired amount of resistance to the halyard so as to control the amount of "pull back" (see section 3.4: Controlling the sail).
- When each batten is approximately 20mm from the furling mandrel, engage the main halyard rope jammer, then flatten the sail further by pulling in on the furling line, over tensioning the luff each time. The batten should lay along the underside of the mandrel, and the sail should flatten along the foot. The

batten in this position avoids fullness creeping into the foot, so where possible reef on each of the batten positions.

- At each of the reef positions mark the main halyard at the jammer position for future height reference.

3.2 Hoisting the sail

Once every 2-3 months we recommend that areas of the bolt rope be coated with Teflon spray, during the hoist, with special attention given to the head of the sail and the batten ends.

Pre check before hoisting the sail:

- Guide the sail into the feeder, and attach the main halyard
- Check that the boom is at the correct angle to the mast
- Ensure the ratchet lock is disengaged
- Release the main sheet, and position the yacht head to wind, so as to unload the sail

Sail hoisting:

- Load the halyard winch with the main halyard and release the furling line rope jammer
- Proceed to hoist the sail, allowing the furling line to pull lightly through the hand
- Hoist the sail fully, or to a reef position
- Lock off the furling line rope jammer
- Tension the main sheet or bear away and proceed to sail

Controlling sail shape (luff tension & outhaul):

The in-built sail controls allow sail shape to be controlled without the use of a cunningham or outhaul, by simply tensioning the furling line.

To flatten the sail for upwind conditions:

Lock off the main halyard rope jammer, then over tension the furling line. This rotates the furling mandrel and draws fullness out of the foot as with an outhaul, at the same time as tensioning the luff as with a cunningham. Do not adjust the main halyard until such time as you wish to furl the sail below this flattened position.

3.3 Furling the sail

Check that the boom is at the correct angle to the mast. Release the main sheet, or position the yacht head to wind, so as to unload the sail.

- Snub the main halyard around a winch or T cleat, to take the halyard load once the jammer is released.
- Release the main halyard rope jammer, ensuring load on the halyard is maintained.
- Pull in on the furling line, as you ease the main halyard. Apply the desired amount of resistance to the halyard so as to control the amount of “pull back” (see 3.4 Controlling the sail).
- Once at the desired reef position, engage the main halyard rope jammer, then flatten the sail further by pulling in on the furling line until the sail is completely flattened.
- Tension the main sheet or bear away and proceed to sail.

A mandrel locking ratchet has been incorporated into the system so the load can be released from the furling line. It does not have to be used, but when engaged, can be extremely useful in the following circumstances:

- When the sail is to be reefed for a long period of time.
- In the event of deck gear, or furling line failure, bring the yacht head to wind and lower the sail by hand.
- Whilst racing the yacht, when an effective outhaul and cunningham is required, it is useful to engage the ratchet to avoid the creep that will occur. Due to the load on the locker, the system will need to be unloaded prior to the locker being disengaged.

3.4 Controlling the sail

Pull back is a term used to refer to the sail gradually working back along the mandrel as it is furled and is visible as lines on the sail, stretching back from the feeder at an angle to the furling mandrel.

A system that is set up and operated correctly will control the amount of pull back and sail shape. Ideally the sail should always furl neatly and directly under the feeder. Indications that the sail is pulling back excessively will be visible by lines stretching through the sail from the feeder.

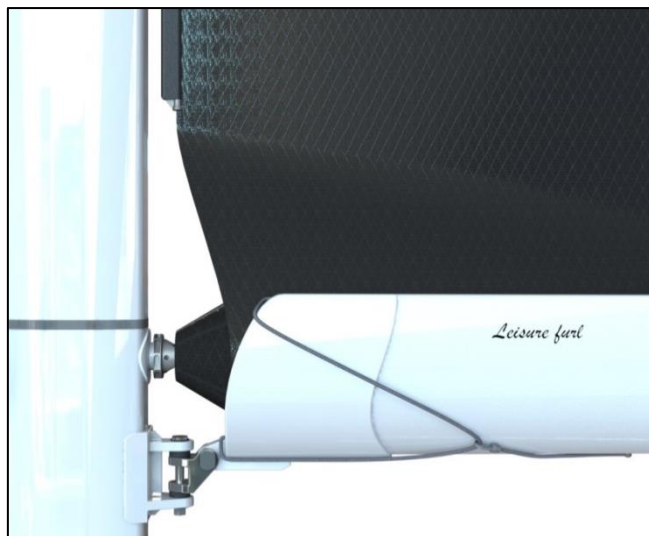

If the sail shows these signs of substantial pull back, reduce the resistance on the main halyard. You will immediately notice that the lines of pull back gradually disappear as you continue.

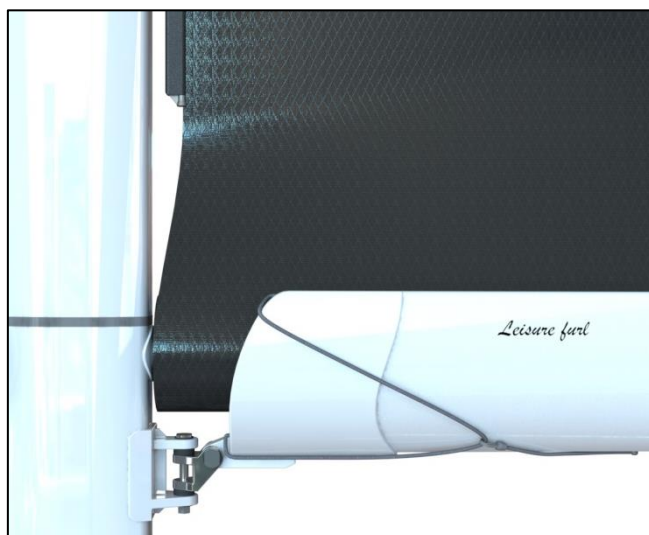

In the instance where the sail works forward, increase the resistance on the main halyard and ensure the sail is unloaded.

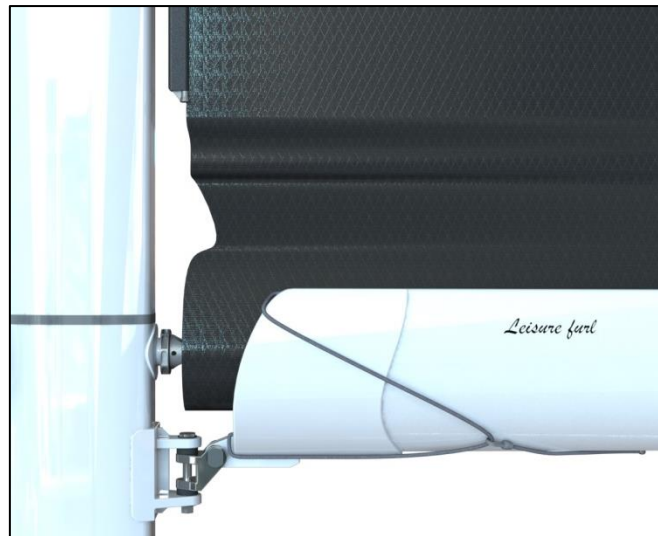

Do not release the main halyard in spurts. The balance of resistance is essential for efficient furling.

If the sail does not appear to be controllable as explained consider the following

- The boom height is not set correctly
- The sail has not been unloaded
- The sail is not positioned correctly on the mandrel

3.5 Sail adjustments

Small adjustments to perfect the furl can be made as follows:

- If the sail shows signs of pull back, without resistance on the halyard, make adjustment at the tack (A), pulling the tack closer into the saddle artificially creates luff round down low. Use the aft tack web if necessary for greater adjustment. This may cause slight distortion at the luff area around the first batten.
- Ease adjustment (C) to return fullness to the foot. Adjustment (B) will not need to be moved from its original setting.
- If the sail works forward as it furls, release adjustment (A) approximately 40mm. Leave adjustment (B) as it is and pull adjustment (C) out by 40mm. Also it may help to pull the topper on a little, past the set mark before furling.

If these adjustments do not rectify the problem, sail modifications may be required. Contact an authorized dealer for further assistance.

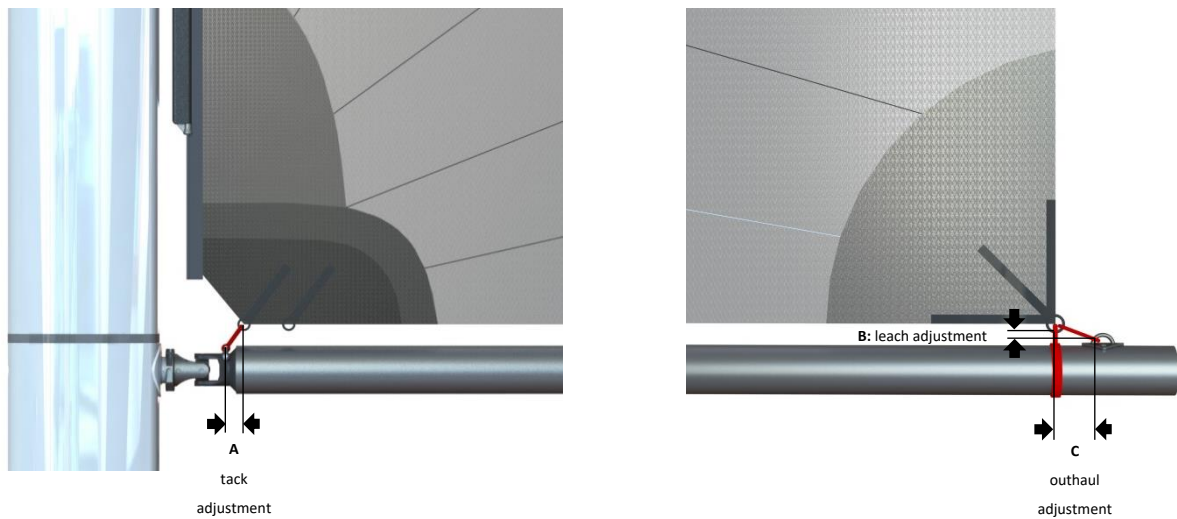

3.6 Operating tips

Use of the Ratchet Lock

A ratchet lock is built into the system to enable manual furling, without the fear of a counter rotation. It has proven useful also when reefed for extended periods. The ratchet will eliminate “creep” which is experienced on the furling line through stretch, and the rope pulling in on the other turns on the spool. Use of the ratchet will also remove load from the deck fittings. To disengage the ratchet lock, simply over tighten the furling line, as you disengage the ratchet lock.

Reef on a batten

Whilst possible to reef at any point of hoist, it remains desirable to reef on a batten as fullness may creep into the foot, and some efficiency lost for up wind sailing.

Luff tension

Luff tension is essential for efficient sail shape in an up wind heavy weather sail. It is a good idea to over tension, rather than under tension, as sail shape will suffer in the later circumstance.

Tension with the furling line

The system uses the main halyard as a means of hoisting the sail only. When luff tension is desired we normally use the furling line. Lock the main halyard off at the desired position, then pull against this with the furling line to achieve a flatter sail with tensioned luff.

Furling down wind

If it is necessary to furl down wind, we introduce a modified procedure to section 3.3 (Furling the sail):

- Square away to a broad reach, or flat run.

- Pull the mainsheet in so the boom is approximately 45° to the centreline.
- Release the vang a little and cause the boom to sky, and pull in on the topper.
- Snub the main halyard off before releasing the main halyard rope jammer. Do not release any of the main halyard.
- Initiate furling without releasing any main halyard, then slowly allow the halyard to pull against the power of the winch. A lot of power will be required.

3.7 Trouble shooting

Sail cannot hoist

- Furling line rope jammer is not disengaged
- Locking ratchet is still engaged
- Furling line has a knot in it somewhere
- Sail has not been fed into the feeder correctly

Sail is hard to hoist

- Sail is partially loaded
- Main halyard is catching somewhere
- Furling line is catching somewhere
- Furling line is jammed in the spool

Sail cannot furl

- Main halyard rope jammer is not disengaged
- Main halyard is jammed somewhere
- Sail is caught somewhere
- At any stage the sail can be lowered by simply releasing the halyard

Sail pushes forward when furling

- Sail has not been unloaded
- Boom height is set to low
- Insufficient halyard resistance applied during the furl
- Sail is positioned to far forward on the mandrel

Sail pulls back excessively when furling

- Boom height is set too high
- Too greater halyard resistance applied
- Sail is positioned to far back on the mandrel

Broken or damaged furling line, deck gear

- Bring the yacht head to wind, lower the sail by hand.

Broken or damaged furling line, deck gear

- Bring the yacht head to wind, insert a winch handle in the spool, engage the locking ratchet, ease the main halyard as the spool is rotated, at the desired level of hoist engage the main halyard rope jammer, continue rotating the spool to tension the luff and flatten the foot.

System makes a noise whilst at anchor

- Take the load of the topping lift or attach a shock cord from the support bracket to the topping lift, then pull tight
- If the sail cover rattles at night, pull the cover along the boom to open.

4. Maintenance

Luff tape

With a new sail on first hoist, apply an even coat of Teflon spray to the full length of the sail on both sides during hoist. After several weeks use, apply a further coat mainly to the head. Thereafter apply to head and luff length of the sail approximately three times a season.

Components

Check at least once per month:

- Vang tang: ensure that all screws are tight
- Mainsheet tangs: screws are tight
- Preventer tangs: is no sign of movement
- Locking ratchet: ensure locker is working well and clean this item at the start of the season with fresh water

Ropes

Main halyard, furling line, sail cover: check for any signs of chafe at rope clutches, rope guides, sheaves etc. Check retrieving line and where lines are joined.

Rig

Track: check the attachment slug nuts are tight and control the sheave box at the mast crane.

Sail

Lashings: check foot lashings for chafe

Inner batten ends, bolt rope: check for any signs of chafe.

5. FAQ

Must I always reef with a batten on the mandrel?

No. You can reef at any point, but the batten on the mandrel is the most efficient position in terms of holding the foot totally flat. The least efficient position is with the batten just outside the boom.

Must I go head to wind, to reef?

No. Under normal circumstances, as with a slab reef, it's desirable to have the main completely unloaded. However, if the boom is out more than 45 degrees though the universal becomes fairly inefficient and quite a lot of power is required.

Do I need to snub the furling line when hoisting?

If the mainsheet is totally free, the furling line only needs to be snubbed if blowing hard. It's good practice to let it run through the hand while hoisting.

Does corrugation in the sail roll damage the sails?

Corrugations are caused by small sail faults, but do not cause any problems. They will gradually disappear as the sail softens up.

For racing, can I get degrees of fullness in the foot and still get luff tension?

Yes. Degrees of fullness can be achieved by pulling small amounts on the furling line but, if this is required, luff tension will need to be achieved with conventional cunningham at full hoist. Remember to ensure it's removed before furling.

Do I have foot control after reefing?

No, it's not required. If correct procedures are followed, the sail will always be totally flat on the foot. If more power is required, simply unwind more sail.

Can I still operate the system if my winch should fail?

Yes. Take controls to another winch.

What do I need to watch in very strong winds?

Only that the mainsheet is totally released and that the bow is not allowed to drop off far enough for the sail to start filling. Also make sure furling line is snubbed when hoisting and main halyard snubbed adequately when furling.

Can I use a solid vang in place of a topper?

Yes. Hydraulic vang's are quite satisfactory, but the angle has to be watched before furling. If using a gas or spring vang without a topper, there must be considerable upward pressure on the boom at its normal furling height, otherwise in a seaway the boom will start bouncing while furling.

Can I get away without a vang if I only cruise?

No. A vang is essential to stop the boom riding up when furling.

6. Glossary of terms

Bolt Rope	The rope used in the luff tape
Clew	The outer corner of the sail between the foot and the leech
Cunningham	The rope that tensions the luff of the sail
Down Wind	With the wind aft of the beam
Feeder	the part below the sail track guiding the bolt rope into the track
Flat Run	With the wind directly from the stern
Foot	The edge of the sail that attaches to the boom
Furling Line	The line which is used to lower the sail
Gooseneck	The fitting attaching the boom to the mast
Head	The top of the sail
Head to wind	With the bow of the yacht directly into the wind
Leech	The back edge of the sail between the clew and the head
Luff track	The sail track on the aft face of the mast
Luff	The front edge of the sail closest to the mast
Luff Tape	The tape at the sail luff which feeds up the sail track
Topping lift	The rope that holds the boom up from the aft end
Main Halyard	The rope that pulls the sail up the mast
Main Sheet	The rope that pulls the boom in and out
Mandrel	The tube that the sail furls around
Outer Bearing	The bearing at the outer end of the mandrel
Outhaul	The tensioning device on a conventional setup
Ratchet	The mandrel locking device that is located at the drive system
Roach	The area of sail that extends out from the leech
Tack angle	The eternal angle between the foot and the luff
Tack	The corner of the sail between the foot and the luff
Universal	The swivelling joint attaching the mandrel to the drive system
Unload the main	Allow the mainsail (and mainsheet) to become totally slack
Vang	The strut or rope purchase system that controls the boom angle

7. Contact details

NETHERLANDS

Made Engineered BV
J.C. van Andelweg 8
7951 DT Staphorst
P. 0031 522 475 664
E. johan@made-engineered.com

UNITED KINGDOM

Advanced Rigging & Hydraulics
Hamble Hampshire
SO31 4NN
P. 0044 238 0454 280
E. info@advancedrigging.co.uk

GREECE

Kafetzidakis Sails
90 Tzavella Avu. Kastella
GR-18533 Piraeus
P. 0030 210 413 7438
E. info@kafetzidakis.gr

ITALY

G&G Rigging srl
Via Mazzini 33
20099 Sesto San Giovanni (Mi)
P. 0039 226 224 232
E. walter&gegrigging.com

MALLORCA

Pro-Rigging
C/ Bernareggi, 2 bajos
07014 Palma de Mallorca
P. 0034 971 592 905
E. rodrigo@pro-rigging.com

GREECE

31100Lefkada
Municipality Marina of Lefkas
P 0030 26450 21461
E: info@waypointsails.com

8. Disclaimer

Content

Made Engineered BV makes every effort to ensure that the material contained in this manual is current, complete and correct. Despite this, errors and mistakes cannot be completely ruled out. Made Engineered BV does not accept liability for the relevance, accuracy or completeness of the information and material offered in this manual. Parts of the pages or the complete publication might be extended, changed or partly deleted by Made Engineered BV without separate announcement.

Copyright

The copyright for any material created by Made Engineered BV is reserved. Any publication or use of objects such as images or texts in other electronic or printed publications is not permitted without the agreement of Made Engineered BV.

Installation

Installation should only be undertaken by an experienced rigger. An experienced rigger should have a thorough knowledge and understanding of general rigging installation principles. Use safety equipment during suitable conditions when installing the Leisure Furl boom. Made Engineered BV does not accept liability for personal injury or property damage resulting from faulty installation. Nor does Made Engineered BV accept warranty claims resulting from faulty installation. Do not install a Leisure Furl boom except on the boat for which it was specifically designed and manufactured.

Operation

Read this manual before attempting to use the Leisure Furl boom. It contains important operating and sail fitting instructions. Learn how to use the Leisure Furl boom before taking your boat out on open waters. The operator is expected to have prior sailing experience, including knowledge of generally recognized safe sailing procedures. The operator should also have an understanding of such basic sailing techniques as hoisting and reefing a sail. Use the Leisure Furl boom at your own risk. Made Engineered BV accepts no liability for personal injury or property damage resulting from your failure to follow the instructions in this manual or generally follow safe sailing procedures.

Legal validity of this disclaimer

This disclaimer is part of the material offered in the owner's handbook. If any of the terms and conditions should be determined invalid by reason of the relevant laws then the remaining terms and conditions shall remain in full effect.